

# Congratulations!

You have selected the KVH Autogyro® Fiber Optic Gyro (FOG).

Fabricated from KVH's proprietary E•Core™ polarization-maintaining fiber, the Autogyro delivers superior fiber optic precision and reliable performance for about the same price as spinning mass gyroscopes.

The KVH Autogyro is an accurate, cost-efficient solution for improving the performance of GPS location and navigation systems that demand continuous coverage and steering information.



Should you have any questions, comments, or suggestions, please direct them to:

KVH Industries, Inc.  
50 Enterprise Center  
Middletown, RI 02842 USA  
tel: (401) 847-3327  
fax: (401) 849-0045  
e-mail: [info@kvh.com](mailto:info@kvh.com)  
Internet: <http://www.kvh.com>

KVH Part No. 54-0130 Rev. A1  
©1999, KVH Industries, Inc.

E•Core™ is a trademark of KVH Industries, Inc.  
KVH® and Autogyro® are registered trademarks of KVH Industries, Inc.

# Table of Contents

1	Introduction .....	1
1.1	<b>Applicability</b> .....	1
1.2	<b>Product Description</b> .....	1
2	Installation .....	4
2.1	<b>Unpacking</b> .....	4
2.2	<b>Preliminary Testing</b> .....	4
2.2.1	Test Procedure .....	6
2.3	<b>Installation Tips</b> .....	7
2.3.1	Attitude and Orientation .....	7
2.3.2	Vehicle Installations .....	7
2.3.3	Power Connection.....	8
2.3.4	Data Connections .....	8
2.3.5	Sensor Zero Offset.....	8
3	Operation .....	9
4	CE Mark .....	10
5	Troubleshooting .....	11
	Appendix A Digital Interface Specification	12
A.1	<b>Digital Data Output Functions</b> .....	12
A.2	<b>Specifications</b> .....	13
A.3	<b>Data Group Structure</b> .....	14
A.4	<b>Message Contents and Scaling</b> .....	15
A.5	<b>Command Structure</b> .....	17
A.6	<b>Serial Interface Operation Notes</b> .....	17

Appendix B .....	Product Information	19
B.1	Patent Protection .....	19

## List of Tables

Table 1.	Autogyro Variants .....	1
Table 2.	Product Specifications .....	2
Table 3.	Electrical Interface .....	5
Table 4.	Troubleshooting.....	11
Table 5.	Specifications.....	13
Table 6.	Data Format .....	14
Table 7.	Message Contents .....	15
Table 8.	Command Codes.....	17

## List of Figures

Figure 1.	Autogyro Interface Control Drawing .....	3
Figure 2.	Test Cable Wiring Diagram (Configured for +12 V Power) .....	6

# 1 Introduction

---

## 1.1 Applicability

This technical manual applies to the KVH Autogyro fiber optic gyroscope for land vehicle navigation and robotics systems. Technical and performance specifications, interfaces, installation guidance, and procedures are provided, as well as a brief troubleshooting guide. The Autogyro is available in several combinations of input power, data output protocols, and GPS input data protocols. These are listed by KVH part number in Table 1.

**Table 1. Autogyro Variants**

KVH Part No.	Power	Serial Out	GPS Input
222140-1-1	12 VDC	RS232	RS232
222140-1-2	12 VDC	RS232	RS422
222140-1-3	12 VDC	RS232	TTL
222140-2-1	12 VDC	RS422	RS232
222140-2-2	12 VDC	RS422	RS422
222140-2-3	12 VDC	RS422	TTL
222140-6-1	24 VDC	RS232	RS232
222140-6-2	24 VDC	RS232	RS422
222140-6-3	24 VDC	RS232	TTL
222140-7-1	24 VDC	RS422	RS232
222140-7-2	24 VDC	RS422	RS422
222140-7-3	24 VDC	RS422	TTL

## 1.2 Product Description

The Autogyro is a single-axis interferometric fiber optic rate sensor, which can incorporate satellite-based radio positioning (GPS) signals for land vehicle navigation applications. Based on E•Core polarization-maintaining fiber and precision fiber optic gyroscope technology, the Autogyro employs solid state signal processing and an all-fiber optical system. The device measures angular rate of rotation and produces a digital signal for rotation rates up to  $\pm 100$  degrees per second maximum. The output rate can be integrated to determine turning angle. Additional interfaces for vehicle ground speed and direction sensing are provided and are included with the output data.

Product specifications are given in Table 2. Note that an arrow on the side of the product shows the sense of rotation corresponding to a positive electrical signal. Please read the entire manual prior to making connections between the unit and your system.

**Table 2. Product Specifications**

Attribute	Specification
<b>Performance</b>	
Input rotation rate (maximum)	
Angle random walk	±100 deg/sec
deg/hr/rt-Hz	20
deg/rt-hr	0.33
Bias Drift	
at fixed temperature	2-4°/hr, 1 sigma
full temperature	0.4°/sec, peak to peak
Scale Factor Linearity	
constant temperature	< 0.5%
full temperature	< 1%
Turn-on Time	1 second
<b>Physical</b>	
Dimensions	115mm x 90mm x 41mm (4.5" x 3.5" x 1.6") excluding connector
Weight	0.25 kg (0.55 lb.)
Operating Temperature	-40°C to +75°C (-40°F to +167°F)
Storage Temperature	-50°C to +85°C (-58°F to +185°F)
Interfaces	See Table 1
Power (Transient and reverse polarity protected)	+9 to +18 VDC (12 VDC nom.), 170 mA or +18 to +36 VDC (24 VDC nom.), 85 mA
Sensor Protocols	
Serial output to host	RS232 or RS422
Serial input from GPS	RS232, RS422 or TTL
Vehicle Inputs	
VSS input (odometer)	+2 to +40 VDC, 0-2500 Hz
Reverse input	+2 to +40 VDC
Connector type	15-pin subminiature D-sub (DA15P)

An interface control drawing (ICD) illustrating the dimensions, connector placement and mounting arrangements is provided in Figure 1.

**Figure 1. Autogyro Interface Control Drawing**

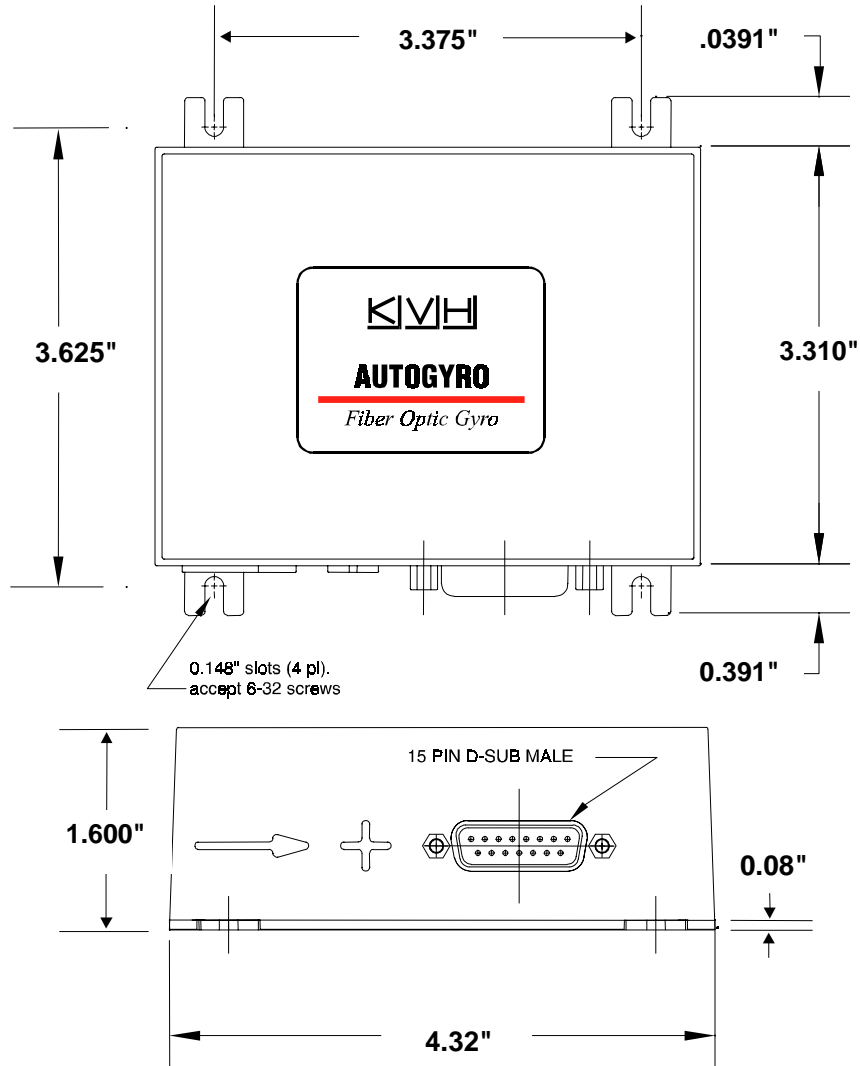

Interface software to run on an MS-DOS compatible PC is provided on a 3½" diskette packaged with the product. Sample source code is provided to illustrate capturing the Autogyro digital data stream. These files may be duplicated and modified for use with the Autogyro, however no warranty is provided. In order to distribute the latest version of the software with each shipment, the instructions for installation and use of the software are found in the README.TXT file on the diskette. This software is prepared specifically for the Autogyro system and should not be used with other KVH fiber optic products. Details of serial message structure and communications interfacing notes are presented in Appendix A, *Digital Interface Specification*.

# 2 Installation

---

## 2.1 Unpacking

The Autogyro is shipped in styrofoam end-blocks within a cardboard carton. We recommend that the packing material be retained in the event that the product must be returned for any reason.

## 2.2 Preliminary Testing

We suggest that you conduct a simple familiarization test if this is your first use of the product. The test will verify proper operation and assist in troubleshooting. The only equipment needed is a +12 VDC or a +24 VDC power supply (depending on your version's power option), a MS-DOS compatible computer and a mating D-sub-style connector wired as shown in Table 3. A GPS-receiver, if available, may be connected to verify the incorporation of GPS position data in the output message format. A cable should be constructed to connect the gyro, power supply and computer as illustrated in Figure 2. A software diskette is shipped with each digital version. It should be installed in accordance with the README.TXT file on the diskette. Please refer to this diskette for a discussion of serial interfacing techniques and sample code to capture data from the digital interface.

**Table 3. Electrical Interface**

<b>Pin</b>	<b>Function</b>	<b>Characteristics</b>
1	DC power (12 VDC systems)*	+ 12 VDC at 250 ma
2	Power common	- - -
3	Rx1+ (from host Tx)	RS232 or RS422, 9600 or 4800 baud
4	Rx1-	RS422 only
5	Rx2+ (from GPS Tx)	RS232, RS422 or TTL, 9600 or 4800 baud
6	Rx2-	RS422 only
7	Tx1+ (to host Rx)	RS232 or RS422, 9600 or 4800 baud
8	Tx1-	RS422 only
9	Tx2+ (GPS)	RS232, RS422 or TTL, 9600 or 4800 baud
10	Tx2-	RS422 only
11	Chassis ground	- - -
12	DC power (24 VDC systems)*	+24VDC at 125ma
13	VSS In (Odometer)	+2 to +40 VDC, 0 to 2500 Hz
14	Reverse In	+2 to +40 VDC
15	Signal Common	- - -

\* The part number suffix denotes the power option for each version (see Table 1. Autogyro Variants).

**Figure 2. Test Cable Wiring Diagram (Configured for +12 V Power)**

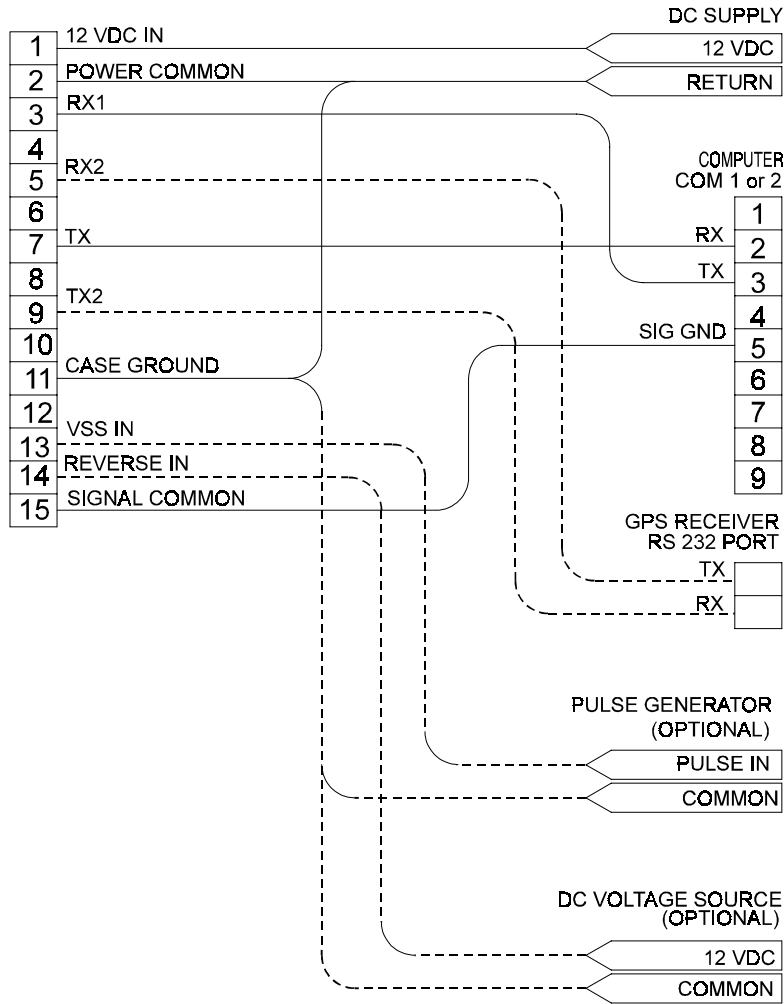

**NOTE:**

VSS IN AND REVERSE IN ARE ASSUMED TO BE REFERENCED TO POWER (VEHICLE) GROUND AND DO NOT NEED A RETURN CONNECTION.

### 2.2.1 Test Procedure

1. Place the module on a flat surface with the mounting surface down.
2. Connect the DC power supply (+12V to pin 1; +24V to pin 12), ground to pins 2 and 11.
3. Open the software application program. Choose the correct host COM port (default is COM1).
4. With the gyro motionless, the indicated rate should be less than approximately 0.2 deg/sec. If no data is received or the data is garbled, check the wiring to ensure that the data lines are properly connected. It may be helpful to use a standard communications program to

visualize the data stream. The parameters are 9600 baud, 8 bits, no parity.

5. Use the AUTOZERO command to enter the at-rest output level.
6. Grasp the gyro and slowly rotate counterclockwise. A positive rate should be indicated. Rotation in the opposite direction results in a negative rate.
7. The FAULT indicator should show false.
8. Apply a  $12 \pm 4$  VDC signal to pin 14 with pin 2 as signal ground. The REVERSE indicator should show TRUE. When the voltage is removed, the indicator should revert to FALSE.
9. Apply a  $12 \pm 4$  VDC pulse signal to pin 13 with pin 2 as signal ground at a rate of less than 2500 pps. The odometer indicator should be one-tenth of the pulse rate applied. (The odometer counts are summed for 0.1 second.)
10. When connecting a GPS receiver, choose the correct baud rate for the GPS input using the test software, and then generate data from the GPS. The GPS data should appear in the GPS window of the test software.

## 2.3 Installation Tips

### 2.3.1 Attitude and Orientation

The axis of rotation is perpendicular to the plane of the mounting surface. The arrow and plus sign on the side of the module casing indicate the direction of rotation resulting in a positive-going output. To minimize output errors and cross coupling to the sensitive axis of the gyro, the mounting plate should be parallel to the plane normal to the rotational axis within five degrees. If this is not observed, the output data will vary as a function of the cosine of the misalignment angle. Note that the module may be either upright or inverted, and the sense of rotation is still indicated by the arrow.

### 2.3.2 Vehicle Installations

The installation site in the vehicle is principally determined by ambient environmental factors. Most installations are in the trunk, or the module may be mounted under a seat. The module should not be exposed to direct sunlight or immersed in fluids. The gyro should not be mounted within 12 inches of any source of strong magnetic fields.

The module's internal circuitry generates a nominal amount of heat which must be conducted away to maintain an operating temperature within specified levels. The baseplate should be in full contact with a metal surface of at least 0.043 m<sup>2</sup> (65 in<sup>2</sup>) surface area. If this is not possible, then a metal plate of the same area should be attached to the baseplate as a heat sink.

### 2.3.3 Power Connection

The rate gyro is designed to be connected to unconditioned vehicle power within specified limits. It is protected against reverse voltage polarity and transients normally experienced in automotive electrical systems. To limit voltage drops, a minimum wire gauge of 24 AWG is suggested for runs under 5 feet and at least 20 AWG for longer runs. Chassis and power grounds should be connected together at the module connector if the mounting location does not provide a good ground. Poor grounds generally result in increased rate noise.

### 2.3.4 Data Connections

The Autogyro can accept odometer pulses up to a maximum of 2550 Hz. Each vehicle type has individual characteristics with respect to the odometer and back-up light. We recommend that these be determined by actual test at the points where they will interface with the Autogyro. Most modern odometers produce a two-level output with 50 percent duty factor and a transition rate proportional to speed. Note that some vehicles employ a variable reluctance type speed sensor and produce a higher pulse count than the Autogyro can accommodate. Please consult your GPS receiver manual for details on interfacing the output data to the gyro.

### 2.3.5 Sensor Zero Offset

As with most sensors, the gyro has a zero offset bias. That is, the output at zero rotational rate usually differs from nominal zero. In some applications it is useful to measure the offset for 5 to 30 seconds when the gyro is known to be stationary and use the average of this measurement as the zero offset. This offset would then be subtracted from all later readings before proceeding with other calculations. The offset can be re-estimated as necessary and appropriate for the system accuracy required. Since the offset is primarily a function of temperature, the user may measure the offset for a given gyro at various temperatures and create a table of offset vs. temperature.

# 3 Operation

---

The Autogyro is self-initializing and is ready for use approximately one second after power is applied. The default baud rate is 9600. The user may change this to 4800 baud, but the setting is effective only as long as operating power is applied to the module. If power is interrupted the baud rate reverts to the default rate of 9600 baud.

# 4 CE Mark

The Autogyro conforms to the European community CE Mark as indicated by the following declaration.

---

---

**KVH Industries, Inc.**  

---

---

**CE Declaration of Conformity**  

---

---

*We, KVH Industries,*  
*declare under our sole responsibility, that the products:*  
**FIBER OPTIC RATE GYROS**

*with product name:*

**KVH AUTOGYRO Fiber Optic Gyro**  
Manufacturer part number: 222140

*Manufactured by*  
**KVH Industries, Inc.**  
**8412 West 185th Street**  
**Tinley Park, Illinois 60477 U.S.A.**

*Is in conformity with the following standards:*  
**EN50081-1 (1992)**  
**EN50082-1 (1992)**  
**EN60555**

**Following the provisions of LVD Directive**  
**9-September 1996**

*Robert J. Kidwell*  
**Robert Kidwell, QC Engineer**

*John Bello*  
**John Bello, Quality Manager**

# 5 Troubleshooting

---

This section is intended to provide a simple means of determining if a problem exists in the Autogyro and assumes that the unit has passed the bench testing described in Section 2.

---



*The Autogyro is supplied as a sealed unit. Breaking the QA seals voids the warranty and may violate the contract under which the unit was supplied.*

*The warranty does not apply if the unit has been damaged by misuse or as the result of service or modification other than by KVH Industries.*

---

**Table 4. Troubleshooting**

Symptom	Possible Cause	Comment
No output	No DC power	Use supplied test software to verify output
	Internal fault	Fault line level (pin 8) should be TTL high (+5VDC)
Erratic or low output	Faulty ground	Ground shield at gyro end only
	Magnetic field near sensor	Check for new wiring or equipment
	Improper output impedance	Check load impedance for minimum 10 k $\Omega$
High noise	Ground loop	Check grounds and grounding

# Appendix A Digital Interface Specification

---

## A.1 Digital Data Output Functions

- Angle change-per-unit time with 16-bit resolution. Full-scale gyro output represents  $\pm 100$  degrees/second velocity when one second of data is integrated. One sample (0.1 second) represents 10 degrees rotation at a maximum  $\pm 100$  degrees/second rotation rate.
- Temperature output with a range of  $-55^{\circ}\text{C}$  to  $+100^{\circ}\text{C}$  and a resolution of  $0.05^{\circ}\text{C}$ .
- 0 output =  $0^{\circ}\text{C}$ .
- Odometer count representing the pulse count of the VSS (Vehicle Speed Sensor) for 0.1 seconds for pulse rates from 0 to 2550 pps. The output count is the difference from the previous count to insure no over/under counts.
- Built-in test (BIT), “vehicle in reverse”, gyro serial number.
- CHECKSUM
- Port 2 input (GPS) is passed through to the host between each group of 8 data bytes. The gyro packet includes a count of characters being passed before the next packet.
- Commands to the gyro and GPS are received continuously through port 1 (the host connection) and echoed to port 2.

## A.2 Specifications

**Table 5. Specifications**

<b>Data Type</b>	<b>Definition/Setting</b>
Interface format	Serial asynchronous, RS232e or RS422
Characters per data group	8
Character format	See Table 6
Baud rate	9600 (default) or 4800
Parity	No parity
Start bits	1 (Low Level)
Stop bits	1 (High Level)
Data bits	8 (Logic 1 = High Level, Logic 0 = Low Level)
Intercharacter spacing	None
Character group spacing	0.1 sec
Character group spacing accuracy	0.001 sec
Group synchronization	Embedded
Connector type	15 pin (D-Subminiature) male

## A.3 Data Group Structure

Characters within an eight-character data group are referred to as Character 1 through 8, with Character 1 being the first character sent. In Table 6, D0 to D7 refers to the bit positions, where D0 is the first bit sent and D7 is the last bit sent per character. Table 6 also shows the position of each data bit in the eight-bit data group. Table 7 shows the contents of each data bit. Scaling factors are discussed after the table.

**Table 6. Data Format**

Character 1	D0	DATA49	Character 5	D0	DATA21
	D1	DATA50		D1	DATA22
	D2	DATA51		D2	DATA23
	D3	DATA52		D3	DATA24
	D4	DATA53		D4	DATA25
	D5	DATA54		D5	DATA26
	D6	DATA55		D6	DATA27
	D7	SYNCBIT (HI)		D7	SYNCBIT (LO)
Character 2	D0	DATA42	Character 6	D0	DATA14
	D1	DATA43		D1	DATA15
	D2	DATA44		D2	DATA16
	D3	DATA45		D3	DATA17
	D4	DATA46		D4	DATA18
	D5	DATA47		D5	DATA19
	D6	DATA48		D6	DATA20
	D7	SYNCBIT (LO)		D7	SYNCBIT (LO)
Character 3	D0	DATA35	Character 7	D0	DATA7
	D1	DATA36		D1	DATA8
	D2	DATA37		D2	DATA9
	D3	DATA38		D3	DATA10
	D4	DATA39		D4	DATA11
	D5	DATA40		D5	DATA12
	D6	DATA41		D6	DATA13
	D7	SYNCBIT (LO)		D7	SYNCBIT (LO)
Character 4	D0	DATA28	Character 8	D0	DATA0
	D1	DATA29		D1	DATA1
	D2	DATA30		D2	DATA2
	D3	DATA31		D3	DATA3
	D4	DATA32		D4	DATA4
	D5	DATA33		D5	DATA5
	D6	DATA34		D6	DATA6
	D7	SYNCBIT (LO)		D7	SYNCBIT (LO)

Gyro rate and temperature data is always in two's complement binary form. The least significant (LSB) is always placed in DATA0. Character synchronization can be verified by

viewing the SYNCBITS in an eight-character group for the 1, 0, 0, 0, 0, 0, 0, 0 sequence prior to using the data.

## A.4 Message Contents and Scaling

**Table 7. Message Contents**

Bit Name	Bit	Bit Name	Bit	Bit Name	Bit
DATA0	R0 (LSB)	DATA19	T3	DATA38	B6
DATA1	R1	DATA20	T4	DATA39	B7
DATA2	R2	DATA21	T5	DATA40	B8
DATA3	R3	DATA22	T6	DATA41	B9
DATA4	R4	<u>DATA23</u>	<u>T7 (MSB)</u>	DATA42	B10
DATA5	R5	DATA24	C0 (LSB)	DATA43	B11
DATA6	R6	DATA25	C1	DATA44	B12
DATA7	R7	DATA26	C2	DATA45	B13
DATA8	R8	DATA27	C3	DATA46	B14
DATA9	R9	DATA28	C4	DATA47	B15
DATA10	R10	DATA29	C5	DATA48	X0
DATA11	R11	DATA30	C6	DATA49	X1
DATA12	R12	<u>DATA31</u>	<u>C7 (MSB)</u>	DATA50	X2
DATA13	R13	DATA32	B0	DATA51	X3
DATA14	R14	DATA33	B1	DATA52	X4
<u>DATA15</u>	<u>R15 (MSB)</u>	DATA34	B2	DATA53	X5
DATA16	T0 (LSB)	DATA35	B3	DATA54	X6
DATA17	T1	DATA36	B4	DATA55	X7
DATA18	T2	DATA37	B5		

R0 to R15 represent angle bits counts with full scale from -10.0 degrees to +9.999695 degrees in one gyro output (0.1 seconds). The least significant bit is 0.000305 degrees. Counts are integrated for one second to determine rate.

T0 to T7 (Message 1) and T0 to T7 (Message 2) provide a temperature word of 12-bits resolution plus sync bits, and are scaled for a range of -55 to +100°C. T0 (LSB) through T6 provide temperature data and T7 is the sync bit (logic HI in Message 1 and logic LO in Message 2). T5 and T6 in Message 2 are held low. Message 1 provides seven low bits and Message 2 provides five high bits, totaling 12 bits. Temperature is transmitted every two messages. The least significant bit is 0.05°C, and a zero out equals 0°C.

C0 to C7 represent odometer counts with the LSB representing a count of 1 and a full scale value of 255. The maximum input rate that can be processed is 2550 Hz.

B0 is the Built-in-Test (BIT) indicator and is logic HI during normal operation.

B1 represents “vehicle in reverse” status and is logic LO when the reverse signal is received from the vehicle.

B2 and B3 are the gyro serial number in 20-bit binary format. The serial number is output in consecutive data messages one bit at a time, starting with the least significant bit (LSB) and ending with the most significant bit (MSB). After the MSB, the process repeats in the next data message with the LSB. The serial number bits are encoded into the SNBIT bit in the message block (B3). The SNSYNC bit (B2) is high when SN0 is output, otherwise it is low.

B4 is the output buffer overflow flag. Its value is zero when no overflow exists and one if there is an overflow in the buffer sending data to the host. This does not occur for gyro data alone, but may occur if the GPS is putting out more than 800 characters per second sustained at 9600 baud (host rate) or 400 characters per second sustained at 4800 baud (host rate). Once the flag is set, powering down the gyro resets it. Bits B8 through B15 contain the buffer output character count for the length of the block of GPS characters output between gyro blocks.

X0 to X7 are the CHECKSUM for the data message. The CHECKSUM is calculated by the gyro processor as the sum of the six other data bytes, modulo 256 and then negated.

When the gyro is in the default mode (always entered on power-up), it outputs turning rate data blocks at a 10 Hz rate. Interleaved with these blocks will be any data received from port 2 (GPS). The interleaved bytes are stored, counted and released after the next rate data block in unaltered 8-bit form. All data from the host port is echoed directly to port 2. If the gyro is set to Transparent Mode (refer to the commands presented on the following page), data is echoed directly in both directions. The gyro monitors the data stream for gyro command blocks.

## A.5 Command Structure

Commands to the gyro are sent as nine bytes of hexadecimal code in this sequence: 01h; 02h; 04h; 08h; 10h; 20h; 40h; command code.

The command codes are as follows:

**Table 8. Command Codes**

01h	Gyro Mode (default): continuous gyro (and GPS) output.
02h	Transparent Mode: no gyro, continuous (not packetized) GPS output.
04h	Software reset.
05h	Set COM1 (host) baud rate to 9600.
06h	Set COM1 (host) baud rate to 4800.
07h	Set port 2 (GPS) baud rate to 9600.
08h	Set port 2 (GPS) baud rate to 4800.

All characters input to the gyro including the command sequences are echoed to port 2. Note that the default baud rate is 9600. Baud rate changes to the optional 4800 rate remain in effect as long as power is applied to the Autogyro. When power is interrupted and then restored the baud rate reverts to the default value. All settings may be returned to their default values by sending the software reset command (04h).

## A.6 Serial Interface Operation Notes

1. In a serial connection of a host, gyro and GPS there are three separate baud rate generators running at slightly different frequencies (even when all are set to run the same baud rate). As a result, if full data rates are maintained (no spacing between bytes) it is possible that characters will be lost.
2. When running a gyro with a 4800 baud GPS connection and a 9600 baud host connection it is necessary to meter the 9600 baud effective data rate down to slightly less than 4800 baud when sending large amounts of data from the host to the GPS receiver.
3. When changing baud rates, a one-second time delay is required to delay additional data transfer to the gyro so the baud rate change can take effect. Baud rate changes may also cause loss of data (either transmit or receive at the gyro) or spurious data to be transferred (the state of data in the UART at time of rate change is indeterminate).
4. When changing from Gyro Mode to Transparent Mode it is possible to receive a binary rate data block after sending the command, since the

data may already be waiting in the buffer. This spurious data may occasionally be seen in the test interface software GPS window after this change is commanded.

# Appendix B Product Information

---

## B.1 Patent Protection

One or more of the following patents protect the technology in KVH fiber optic rate sensors:

Australia	514,840	Japan	1,561,748
	562,456		1,870,145
	574,343		2,076,012
	582,425		2,509,580
	584,745		
	594,847	Netherlands	0 196 168
	661,187		0 021 712
			0 215 674
Canada	1,143,197	United States	4,307,938
	1,234,005		4,557,551
	1,236,322		4,589,725
	1,248,383		4,589,728
	1,240,015		4,668,264
	1,267,790		4,669,814
	1,270,055		4,697,876
	1,293,397		4,712,866
	1,304,566		4,755,021
	2,138,814		4,784,454
France	0 021 712		4,818,071
	0 127 257		4,950,318
	0 196 168		5,074,665
	0 215 674		5,323,255
	0 254 462		5,340,371
			5,437,000
Germany	P30 64 691.4		5,444,534
	P34 84 284.5		5,481,358
	P36 71 972.2		5,512,904
	P36 88 959.8		5,552,887
	P37 76 017.3		
		United Kingdom	0 196 168
Italy	0 021 712		0 021 712
	67,166-BE/92		0 127 257
	67,730-BE/91		0 215 674
	69,253-BE/93		0 254 462
			1,599,345